

Technical Instructions

for the launch amplifiers

SBK 3301 NF, SBK 3302 NF and SBK 3305 NF

the cascadable multiswitches

SMK 3342 F, SMK 3362 F, SMK 3382 F

and the repeater amplifiers

NVF 3322 SR and NVF 3323 SR

Important: Please observe the following instructions !



Installation is only permitted in dry rooms and upon a non-combustible surface. Ensure that there is adequate air circulation. The permissible ambient temperature range is: -20°C to $+50^{\circ}\text{C}$ (253 K to 323 K). Wall mounting only with power supply housing on the left or on the right side (horizontal mounting).



The components meet the more stringent screening requirements according to amendment 1 of EN 50083-2, quality grade A.



All Components are equipped with an earthing terminal for connecting to the main potential equalization.



SPAUN electronic confirms the keeping of the EMC requirements in accordance to the CENELEC standard EN 50083-2 and the keeping of the safety requirements in accordance to the CENELEC standard EN 50083-1 by the CE sign.



N12382

The C-Tick mark shows the conformity of the device with the EMC regulations of the ACA. (ACA requirements bases on CISPR, CENELEC and IEC standards).

Setting instructions:

Power Supply to LNB:



SBK 3301 NF and SBK 3302 NF

Supply modes:	Remote voltage V Input to LNB	Remote voltage H Input to LNB
12 V	12 V	12 V
18 V	12 V	18 V
22 kHz	12 V + 22 kHz	18 V + 22 kHz

Factory settings: 12 V

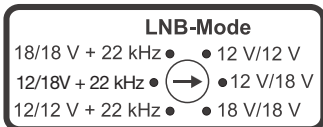

Factory settings: 12 V / 12 V

SBK 3305 NF

Supply modes:	Remote voltage V Input to LNB	Remote voltage H Input to LNB
12 V / 12 V	12 V	12 V
12 V / 18 V	12 V	18 V
18 V / 18 V	18 V	18 V
12 V / 12 V + 22 kHz	12 V + 22 kHz	12 V + 22 kHz
12 V / 18 V + 22 kHz	12 V + 22 kHz	18 V + 22 kHz
18 V / 18 V + 22 kHz	18 V + 22 kHz	18 V + 22 kHz

The LNB remote current must not exceed a total of 0,4 A.

Level Adjusters:

- 8 dB



SAT

SAT:

The launch amplifiers (SBK...) have separate level adjusters for each SAT IF Input. The remote powered repeater amplifiers (NVF...) work with a single synchronous level adjuster for all SAT IF Inputs.

The input levels of the **SBK 3301 NF**, **SBK 3302 NF** and **NVF 3322 SR** can be reduced by 0 ... 8 dB.

The input level of the **SBK 3305 NF** can be reduced by 0 ... 10 dB and the **NVF 3323 SR** can be adjusted by 0 ... 7 dB; **Factory settings: 0 dB**.

Terrestrial:

The launch amplifier **SBK 3302 NF** is equipped with an adjustable attenuator in order to adjust the level of the terrestrial or CATV signals. The input levels can be reduced in active mode by 0 ... 10 dB. The signal is not amplified in the "passive" setting.

Terr. - 10 dB



The launch amplifier **SBK 3305 NF** is equipped with an adjustable attenuator in order to adjust the level of the terrestrial or CATV signals. The input levels can be reduced by 0 ... 12 dB. No passive setting for the terrestrial amplifier. **Factory settings: 0 dB**.

Power Supply:

The launch amplifiers have internal, energy-saving, switched mode power supplies.
U~: 100-240 V \pm 10 % / 50-60 Hz.

Power consumption (with max. remote current):

	SBK 3301 NF	SBK 3302 NF	SBK 3305 NF
SAT active Terr. passive	14,5 W	28,5 W	-
SAT active Terr. active	-	32 W	43 W

Repeater amplifier supply:

The **SBK 3301 NF** is **not** designed to supply a remote powered network repeater amplifier.

The launch amplifiers **SBK 3302 NF** and **SBK 3305 NF** provides a continuous remote voltage at the output trunklines to supply a network repeater amplifier.

Attention!

Use the three DC-blockers attached to the launch amplifiers, in case of connecting equipment that may cause a DC shortcut at the trunkline outputs.

For the **SBK 3302 NF** the maximum permissible total current delivery is 650 mA at 18 V.
The current must not exceed 500 mA per socket.

The **SBK 3305 NF** delivers a maximum permissible total current of 1000 mA at 18 V.
The current must not exceed 500 mA per socket.

The **SBK 3302 NF** or the **SBK 3305 NF** can feed only **one** remote powered repeater amplifier of the types **NVF 3322 SR** or **NVF 3323 SR**.

Repeater amplifier consumption:

The repeater amplifier **NVF 3322 SR** and the **NVF 3323 SR** can be remote powered from each trunkline.

Remote power voltage range: 12 V to 20 V.

Remote power current consumption:	NVF 3322 SR:	515 mA @ 15 ... 20 V.
	NVF 3323 SR:	510 mA @ 15 V 420 mA @ 19 V

The remote current must not exceed 500 mA per socket.

Terrestrial:

The launch amplifier **SBK 3301 NF** has a passive terrestrial (5 ... 862 MHz) with a through loss of max. 3,5 dB.

This means the **SBK 3301 NF** is return path compatible.

The terrestrial inputs of the **SBK 3302 NF** and **NVF 3322 SR / NVF 3323 SR** have adjustable attenuators.

The amplifier unit (47 ... 862 MHz) is designed CATV compatible, by the use of a push-pull power amplifier. The terrestrial signal can also be passed through passively. To do this, the adjustable attenuator must be turned counter clockwise to the limit. The terrestrial amplifier then will be bypassed, the through loss is max. 4 dB.

At the same time, the frequency range expands to 5 ... 862 MHz; this means the devices are return path compatible.

The terrestrial input of the **SBK 3305 NF** has an adjustable attenuator. The amplifier unit (47 ... 862 MHz) is designed CATV compatible, by the use of a push-pull power amplifier.

It is not recommended to connect aerials directly to the terrestrial input. Selective devices should be used to avoid interference, e.g. FMP 30, VFM.. F or MBV .. PF.

SAT IF Distribution:

The maximum input level is typically 83 dB μ V for each launch amplifier, if the adjustable attenuator is turned on lowest attenuation and with full transponder load. The IF signals are to be fed into the launch amplifier and the multiswitches in accordance to the labeling so that the logical assignment of the IF signals matches the switching criteria.

Maximum output levels of the Launch amplifiers:

SBK 3301 NF	Range		
	950 ... 2200 MHz	110	dB μ V @ 35 dB IMA ₃ / EN 50083-3
950 ... 2200 MHz	110	dB μ V @ 35 dB IMA ₂ / EN 50083-3	

SBK 3302 NF	Range	dB μ V @ 60 dB / EN 50083-3				
		IMA ₃	IMA ₂	CTB	CSO	CENELEC-Group
	47 ... 450 MHz	110	110	108	113	A: 19 Ch
	47 ... 606 MHz	110	110	104	108	C: 29 Ch
	47 ... 862 MHz	109	109	100	110	E: 42 Ch
	950 ... 2200 MHz	110	35 dB IMA ₃ / EN 50083-3			
	950 ... 2200 MHz	110	35 dB IMA ₂ / EN 50083-3			

SBK 3305 NF	Range	dB μ V @ 60 dB / EN 50083-3				
		IMA ₃	IMA ₂	CTB	CSO	CENELEC-Group
	40 ... 450 MHz	117	120	112	122	A: 19 Ch
	40 ... 606 MHz	117	120	110	117	C: 29 Ch
	40 ... 862 MHz	117	120	107	115	E: 42 Ch
	950 ... 2200 MHz	117	35 dB IMA ₃ / EN 50083-3			
	950 ... 2200 MHz	117	35 dB IMA ₂ / EN 50083-3			

Maximum output levels of the remote powered network repeater amplifiers:

NVF 3322 SR	Range	dB μ V @ 60 dB / EN 50083-3				
		IMA ₃	IMA ₂	CTB	CSO	CENELEC-Group
	47 ... 450 MHz	109	109	106	111	A: 19 Ch
	47 ... 606 MHz	109	109	102	105	C: 29 Ch
	47 ... 862 MHz	109	109	99	102	E: 42 Ch
	950 ... 2200 MHz	110	35 dB IMA ₃ / EN 50083-3			
	950 ... 2200 MHz	110	35 dB IMA ₂ / EN 50083-3			

NVF 3323 SR	Range	dB μ V @ 60 dB / EN 50083-3				
		IMA ₃	IMA ₂	CTB	CSO	CENELEC-Group
	47 ... 450 MHz	115	115	115	112	A: 19 Ch
	47 ... 606 MHz	115	115	113	110	C: 29 Ch
	47 ... 862 MHz	115	115	109	105	E: 42 Ch
	950 ... 2200 MHz	115	35 dB IMA ₃ / EN 50083-3			
	950 ... 2200 MHz	115	35 dB IMA ₂ / EN 50083-3			

Cascadable multiswitches: SMK 3342 F, SMK 3362 F and SMK 3382 F

These modules are the switching components of the cascadable IF distribution system. They have to be placed in the line behind the launch amplifiers. They also support the terrestrial signal distribution and they are return path compatible.

In case of a central distribution, the components can be interconnected with ZSV 2 S push-on connectors, or they may also be installed separated from each another as "storey distributors".

The trunklines of the cascade have to be terminated with DC-insulated resistors (ZFR 75 DC). These DC insulated resistors are supplied with the launch amplifiers.

Typically a number 3 or 4 cascadable multiswitches can be installed in a line without using a repeater amplifier. To increase the number of outputs in one cascade line a repeater amp can be used (type NVF 3322 SR or NVF 3323 SR). The current consumption of the cascadable multiswitches for switching is 25 mA at the used output.

Technical data:

Type designation	SMK 3342 F	SMK 3362 F	SMK 3382 F
Order no.	842404	842405	842406
Frequency range	1 x 5 ... 862 MHz / 2 x 950 ... 2200 MHz		
Number of subscribers	4	6	8
Through loss SAT	1 ... 2 dB	3,5 ... 4,5 dB	3,5 ... 4,5 dB
Through loss Terr.	4 dB	6 dB	7 dB
Tap loss SAT	21 ... 17 dB		
Tap loss Terr.	20 dB		
Switching Isolation V / H	> 26 dB		
Insulation: Trunkline / Trunkline Tap / Tap	> 40 dB > 26 dB		
Current requirement per receiver	max. 25 mA		
Dimensions	W = 140 mm H = 90 mm D = 38 mm	W = 140 mm H = 153 mm D = 38 mm	

Your partner for Australia:

JONSA ELLIES

1 A Carnarvon St.
Silverwater NSW
2128 Australia

PO Box 6147
Silverwater NSW
1811 Australia

Phone: +61 2 9648 1132
sales@jonsa.com.au

Fax: +61 2 9648 1135
www.jonsa.com.au

Application Diagrams:

SMATV networks

→ Star distribution

Terrestrial and 2 SAT IF signals

24 Subscribers / Receiver:

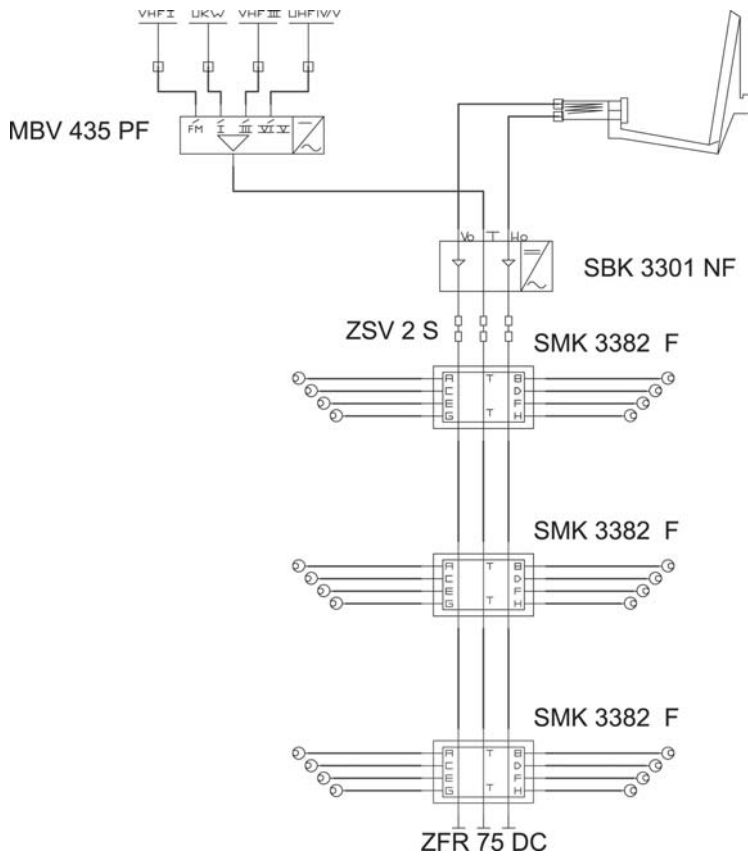

48 Subscribers / Receiver:

